

MENDELSON, J. 1988. Communal roosting and feeding conditions in Blackshouldered Kites. *Ostrich* 59:73-75.

WAIAN, L. B. AND R. C. STENDALL. 1970. The White-tailed Kite in California, with observations on the Santa Barbara population. *Cal. Fish Game* 56:188-198.

4554 Shetland Green Road, Alexandria, VA 22312. Address of second author: 2188 Hackberry Circle, Longmont, CO 80501.

Received 16 September 1988; accepted 30 June 1989

J. Raptor Res. 23(3):117-120

© 1989 The Raptor Research Foundation, Inc.

THE BARTOS TRAP: A NEW RAPTOR TRAP

ROBERT BARTOS, PENNY OLSEN AND JERRY OLSEN

Many effective means of live trapping birds of prey are available, including bal-chatri [Berger, D. D. and H. C. Mueller. 1959. The Bal-Chatri: A trap for birds of prey. *Bird Banding* 30:18-26; Olsen, J. and P. Woollard. 1975. The use of the bal-chatri in banding. *Canberra Bird Notes* 3(4):8-9], noose carpet, mist net and dho-gazza (e.g., Beebe, F. L. and H. M. Webster. 1964. North American falconry

and hunting hawks. World Press, Colorado), Swedish Goshawk trap (e.g., Beebe and Webster 1964) and its derivatives, and "flip trap" [e.g., Cam-Hardy universal raptor trap, Cam. G. R. 1985. A universal raptor trap. *Corella* 9(2):55-58]. The most appropriate trap will depend upon target species and circumstances. Sometimes setting a variety of traps is useful to increase the chances

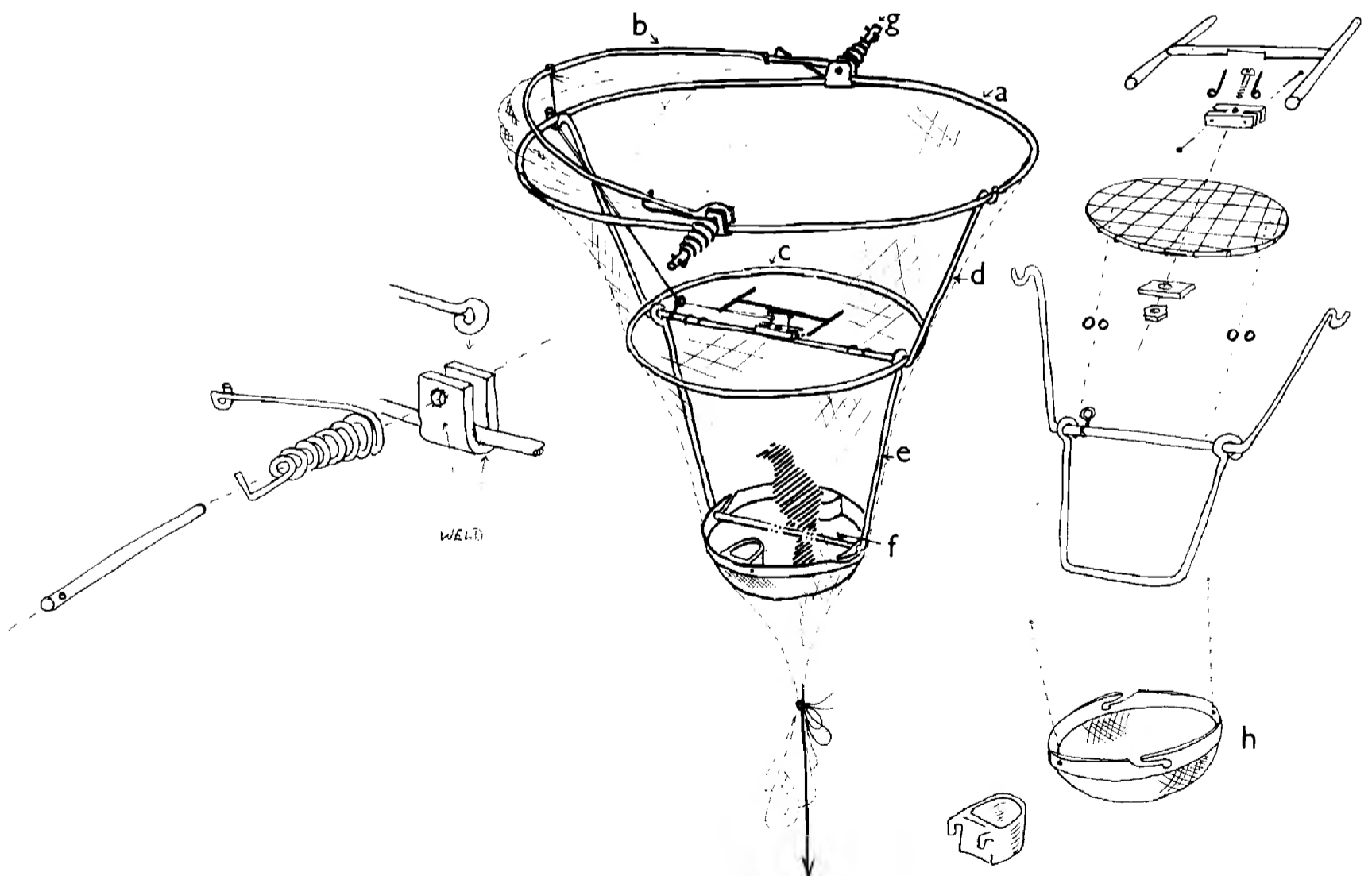

Figure 1. Assembly instructions for the Bartos Trap.

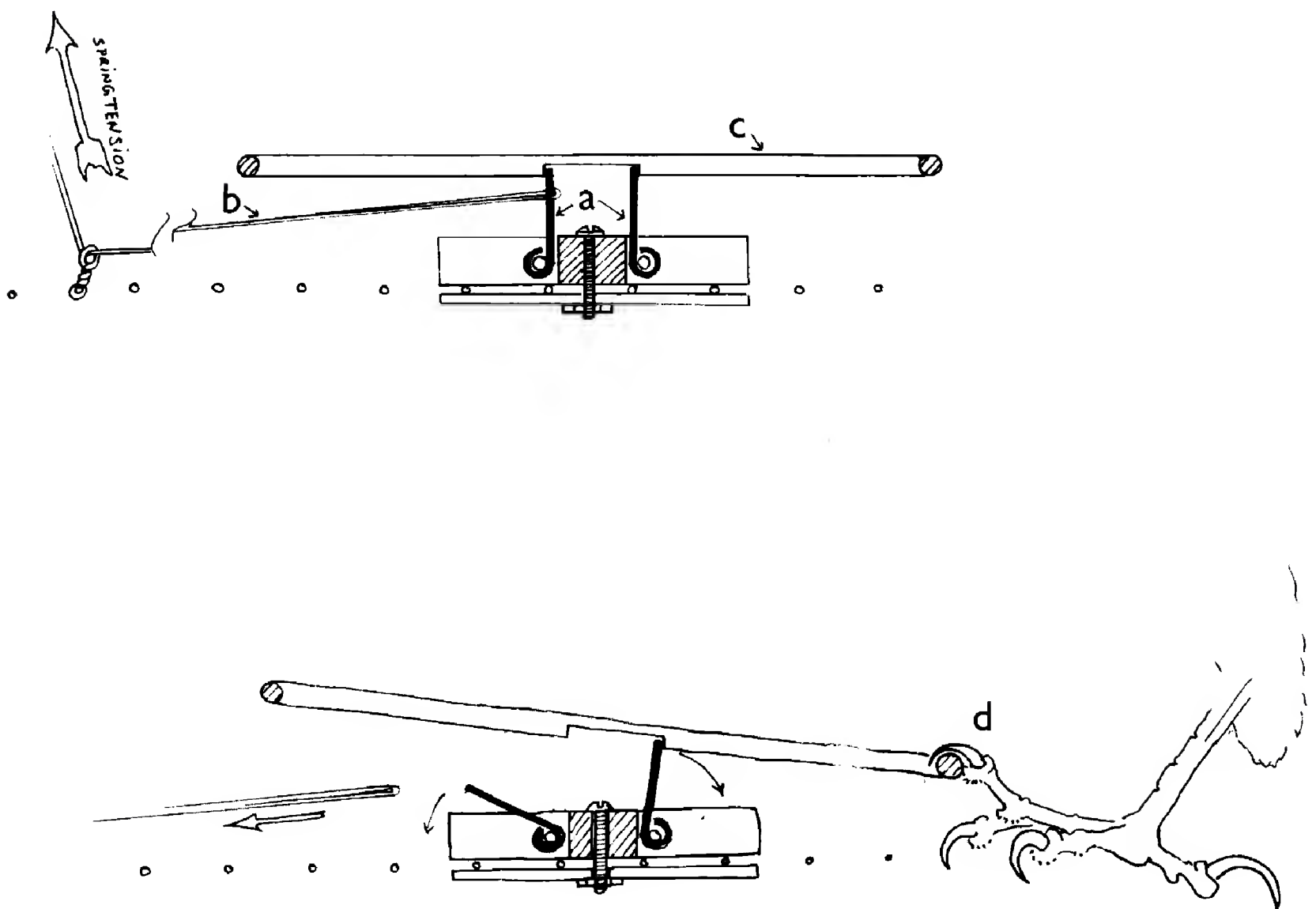

Figure 2. Assembly instructions for trigger mechanism.

of capturing a particular raptor, or, when recapture is necessary, to overcome the problem of avoidance of a type of trap in which the raptor has already been captured.

Here we report on a versatile and convenient new trap, designed by Robert Bartos, which has several unique characteristics. The Bartos Trap can be suspended at almost any height (e.g., in a building or in a tree near a nest), to capture species reluctant to venture to the ground. Once captured the raptor is enclosed: unlikely to injure itself and safe from predators. The trap need not be attended and thus has several advantages over a mist net type of trap. When assembled in alternative form and set on the ground, the trap is similar to the "flip trap" (see above). Further, the trap can be collapsed flat for easy carrying.

So far we have used the trap to capture only 2 particular individual raptors: a Collared Sparrowhawk (*Accipiter cirrhocephalus*) unable to escape from a warehouse and a Boobook Owl (*Ninox novaeseelandiae*) in a wooded paddock, recaptured for removal of a radio transmitter. In both cases the trap was left and the raptor captured on our return about 2 hr later. We have also caught Kookaburras (*Dacelo gigas*) and Pied Currawongs (*Strepera graculina*), and, with a sparrow as a lure and the trigger set fine, House Sparrows (*Passer domesticus*).

Trap Construction. The main ring (Fig. 1a), bow arm (Fig. 1b), and divider frame (Fig. 1c) are made from soldered metal rod approximately 4 mm dia. Remaining sections of the frame are heavy gauge wire (approximately 10–12 gauge). An inexpensive fishing scoop net (black tetron or similar) forms separate netting compartments for raptor and lure. The net's diameter at full stretch determines the size of the elliptical main ring (in our trap about 62 cm × 57 cm) and bow arm. In our trap the divider is about 33 cm dia, the spreader arms (Fig. 1d) 21 cm long, and the length of the swing for the lure compartment 12 cm (Fig. 1e) and lure perch (Fig. 1f) 21 cm. The base of the lure compartment (Fig. 1h) is simply a wire kitchen strainer, in our case 21 cm in diameter. Springs for the bow net (Fig. 1g) are modified springs from a rat trap. We covered the bow ring and adjoining half of the main ring with refrigeration tubing to lessen the chance of injury to the raptor by the closing bow.

The trap is assembled as shown (Fig. 1). Wire mesh is tied to the divider ring to form the base of the top compartment and protect the lure. Spreader arms (Fig. 1d) are attached to the divider so that they can be folded; arms clip onto the main ring and can be removed for folding. The swing (Fig. 1e) can also be clipped on or left off. The

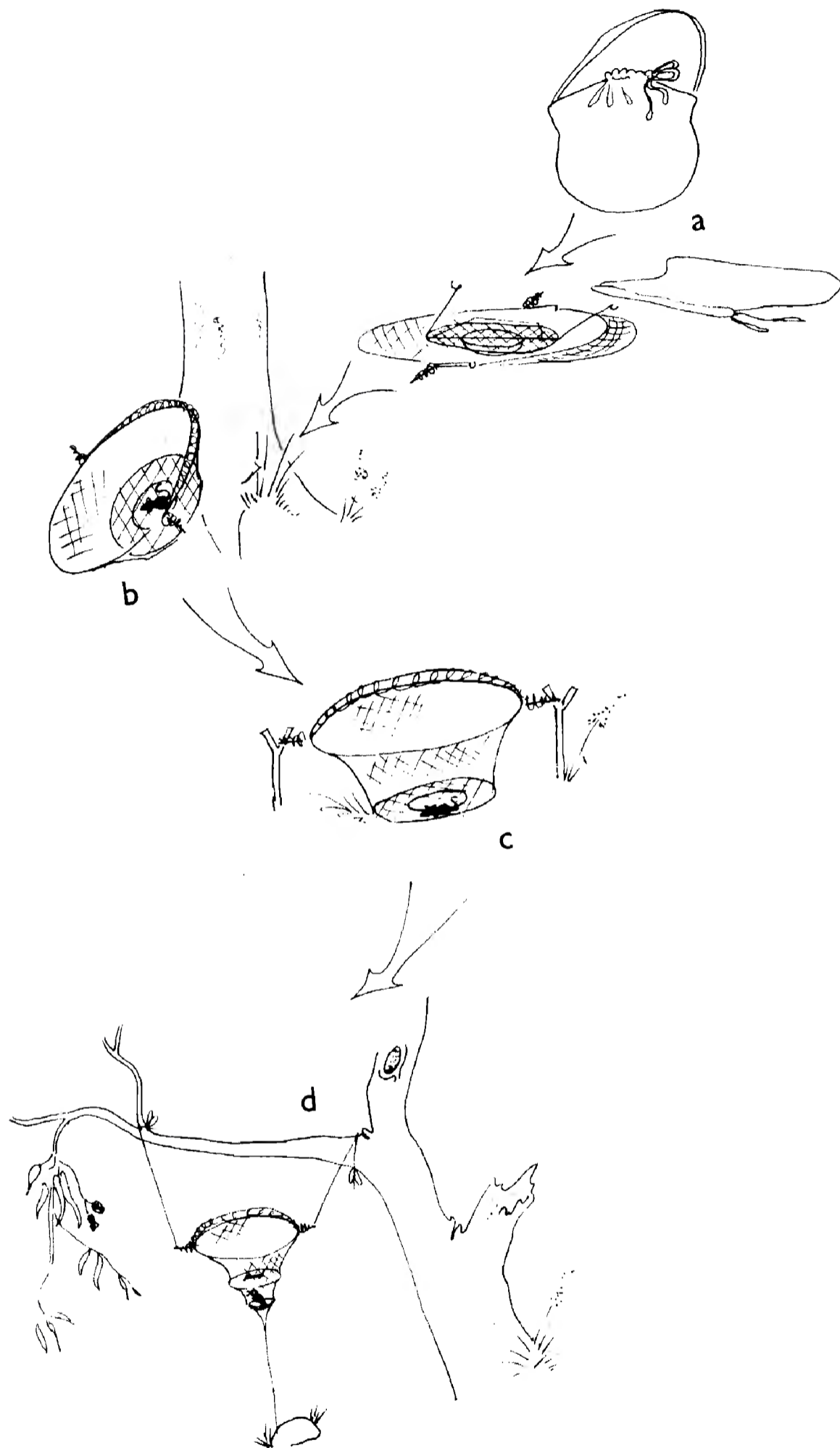

Figure 3. Various trap settings: a. folded for transport; b. set angled on the ground; c. set flat on the ground; d. set hanging.



Figure 4. The Bartos Trap: A. set on the ground; B. set hanging from a tree.

strainer must have bayonet slits cut into it (Fig. 1h) and can be clipped either to the frame, beneath the trigger, or to the swing.

Once the wire frame is set together, netting can be stretched over and secured with string around the main ring, bow net (so that the netting is taught when the bow is closed) and divider. The rest of the netting hangs down and can be secured, as required, depending upon the way the trap is used.

The trigger device (Fig. 2, shown in cross section) is screwed to the divider frame over the top of the wire. The trigger setting fingers (Fig. 2a) are made from the setting rod of a mouse trap, or similar material (about 2 cm long on our trap). The trigger string (Fig. 2b) can be set low on the fingers to catch small birds (e.g., sparrows) or higher (for maximum tension) to catch large raptors. We made the trigger "perch" (Fig. 2c) from wood.

Use of Trap. A lure is placed in the lower compartment: either a mouse or small passerine if set on the ground, or bird if set hanging. In an attempt to capture the lure a raptor enters the trap through the top and perches on or trips the trigger device (Fig. 2d). The bow net then quickly flips closed. The bird is secured in a strong netting compartment that is nonabrasive, unlike the wire netting used on some other types of trap, and is unlikely to damage the cere or break flight feathers.

The trap is collapsed flat for easy transport (Fig. 3) and can be assembled in 2 ways: 1) with the lure compartment clipped directly beneath the divider for use on the ground, and set either angled toward the target bird (Fig. 3b) or flat (Fig. 3c, 4a); or 2) with the lure compartment hanging beneath the divider and the netting stretched more fully and set suspended (Fig. 3d, 4b). Robert Bartos will provide further details and accept orders for the trap from licensed trappers.

Lot 5 Lamont Close, Mardi, N.S.W. 2259, AUSTRALIA. Address of second author: P.O. Box 84 Lynham, A.C.T. 2602, AUSTRALIA. Address of third author: R.M.B. 1705 Read Rd., Sutton, N.S.W. 2620, AUSTRALIA.

Received 8 December 1988; accepted 30 June 1989